



ACTIVE SYSTEM MANAGEMENT UNDER UNCERTAINTY

Shakah G. ¹⁾, Krasnoproshin V.V. ²⁾, Valvachev A.N. ³⁾

¹⁾ Irbed National University:
21110 Jordan, P.O.Box 2600, Jordan,
e-mail: warsaw2000@yahoo.com

²⁾ Belarus State University,
Nezavisimosti av. 4, 220050 Minsk, Belarus,
e-mail: krasnoproshin@bsu.by, van_955@mail.ru

Abstract: *The paper describes the use of fuzzy set theory and theory of active systems for constructing systems that manage geographically distributed organizations under uncertainty. Unification algorithms for fuzzy data and their use for choosing management of distant objects are presented.*

Keywords: *decision making, active systems, fuzzy sets, pattern recognition.*

INTRODUCTION

Adaptation of socio-economic systems to conditions of the forming information and communication environment under global uncertainty requires revision of traditional management methods. In particular, a topical problem is prompt management of geographically distributed organizations consisting of a center and numerous distant divisions. Operative tasks are gradually forcing out traditional planned ones, because the role of the former (as a result of globalization and acceleration of business processes) has considerably increased and become the main one for supporting homeostasis of an organization.

Theoretical questions of organization management are studied in the works of M.D. Mesarovich [1], V.N. Burkov, D.A. Novikov [2], etc. Architecture of computer control systems is presented in the works of A.V. Tsaregorodtsev [3], G. Klir [4], etc. Numerous models and algorithms are proposed. The models and algorithms are mostly of particular nature or rather complex and rigid to data requirements, thus making difficult their implementation in computer technologies and narrowing the range of practical problems being solved.

The paper presents a mechanism for management of geographically distributed organizations on the basis of fuzzy information. The mechanism can be realized both in Internet infrastructure and departmental nets.

1. PROBLEM ANALYSIS AND STATEMENT

The problem of constructing systems for management of Geographically Distributed Organizations (GDO) is rather complex due to several reasons, the main ones are [6,7]: 1) mechanism for choosing management in GDO is analogous to decision making in biological systems, i.e. not only possible states of GDO and algorithms for their recognition are varied, but also the number and semantics of diagnostic variables; 2) distant divisions have their own behavior, which can contradict interests of the center; 3) the state of GDO as a whole and separate divisions can hardly be determined by exact numeric methods, because initial data is heterogeneous and fuzzy, the use of statistical methods is impossible due to the lack of significant time interval in operative tasks; 4) the number of objects can reach several tens of thousands (e.g. in The Ministry for Emergency Situations), but the time for choosing management by the center, as a rule, is minimum and is a critical parameter for GDO homeostasis.

Let's formulate a general problem of constructing GDO management system, taking into consideration the above-mentioned problems.

Let there is environment E , in which organization F operates, consisting of center C and a set of distant objects P^1, P^2, P^n . Change of the environment generates problem S , influencing the homeostasis of F . The change is characterized by variables X^1, X^2, X^m and requires management U^1, U^2, U^k (known to

the center) for objects P^1, P^2, P^n in order to keep the objects in one of the predetermined set of states V^1, V^2, V^k . It is necessary to develop a mechanism for choosing management U^i for object P^i on the basis of X^1, X^2, X^m , invariant to the number of objects.

Solution requirements:

- the number of possible object states varies depending on problem semantics;
- the number of variables X^1, X^2, X^m varies depending on problem semantics;
- values of parameters X^1, X^2, X^m are heterogeneous (string, integer, real, boolean).

Assumptions:

- center and objects are positioned in Internet infrastructure;
- objects are interested in submitting the required information without distortion to the center;
- there is a mechanism for realizing the chosen management by the center.

The solution within the specified requirements and assumptions should be simple, transparent, flexible, realizable on standard IBM PC in OS Windows and understandable for managers in the center as well as average users in distant objects.

2. SOLUTION

First of all, let's determine the theoretical basis of the solution. The existence of divisions with their own behavior in GDO makes it possible to use the theory of active systems [2,4] as the theoretical basis. Fuzziness in data for determining states of GDO components makes it reasonable to use the theory of fuzzy sets [5]. Let's normalize the use of components of these theories with axioms following from the problem semantics:

Axiom 1. The center can specify a final set of GDO states relevant to the problem.

Axiom 2. The center can specify a set of diagnostic variables determining GDO states.

Axiom 3. The center can specify numerous control relevant to GDO states.

Axiom 4. Sets of GDO states and objects are identical.

Axiom 5. GDO state depends on object states.

Axiom 6. Objects are not interested in distortion of information submitted to the center.

Axioms 1-5 are of absolute nature. Axiom 6 is relative but this drawback can be easily eliminated by the center due to the use of well developed methods of hidden management.

Let's use a standard model of an active system as a system framework. The model is specified by enumeration of system participants, their objectives, properties and structure of their relations [2]:

$$MPO = (C, P^1, P^2, P^n, Structure) \quad (1)$$

where: Structure describes relations between the center and objects. In our case it is a fan-type structure [2] typical for the majority of practical management problems.

Models of MPO components, which have been oriented to representation in interfaces, and the corresponding data structures are shown below.

Center model:

$$C = (adrC, adrP, admC, BA, BD, Buffer, S, X, Sost, U, DC) \quad (2)$$

where: $adrC$ is center address in Internet; $AdrP$ are addresses of controlled objects; $admC$ is center administration; BA is a base of algorithms for data formalization and decision making; BD is a database; $Buffer$ is a buffer; S is a problem; X are diagnostic variables; $Sost$ is a state; U is management; DC is a mediator enabling information exchange between the center and objects.

Mediator model:

$$CD = (adrP^i, adrC, S, Q, X, <X>, Box) \quad (3)$$

where: Q are queries for obtaining values of X ; $<X>$ are values of X ; Box is a container that is often used in practice for transferring additional information. For example, in offshore programming it can be a fragment of the developed system requested to the center for expert assessment of system readiness. In each problem of management selection, mediator CD participates two times for each object (see Fig.1).

Object management model:

$$P^i = <adrP^i, admP^i> \quad (4)$$

where: $adrP^i$ is object address in Internet; $admP^i$ is center administration.

Library of BA contains four algorithms realizing main steps of management problem solution within the above-mentioned models.

Algorithm F1 (Fig.1) (in dialog with an expert) forms values of V, U, X, Q , a subset of bifurcational variables \underline{x} , membership functions μ^1 for X and μ^2 for \underline{x} . A set of reference vectors M is constructed automatically on the basis of V and X properties. The query Q, X is sent to the object.

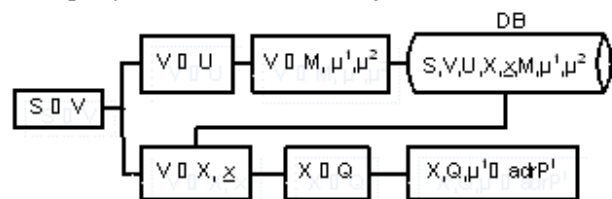

Fig.1 – Model construction algorithm scheme

Algorithm F2 (Fig.2) (in the interactive mode) forms a fuzzy pattern $\langle X \rangle$, characterizing a distant object, that is sent to the center.

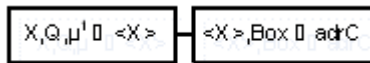

Fig.2 – Enrichment model algorithm scheme

Algorithm F3 (Fig.3) compares pattern $\langle X \rangle$ with each vector from reference matrix M, choosing the vector the distance to which is minimum. State V is selected according to the number of the vector. Then, algorithm F4 corrects the number of V with the help of algorithm μ^2 in accordance with values of bifurcational variables \underline{x} . Management U is chosen according to the specified number U.

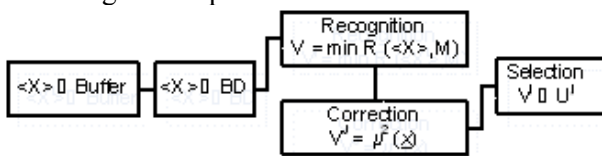

Fig.3 – Scheme of recognition and management selection algorithm

The presented algorithms are of open nature and can be realized within different approaches. The example below is oriented to closed departmental nets.

3. SYSTEM ARCHITECTURE

An architecture (see Fig.4) is proposed for complex realization of the developed models and algorithms. The architecture includes two program modules (center interface and mediator interface made integral with object interface) and a database.

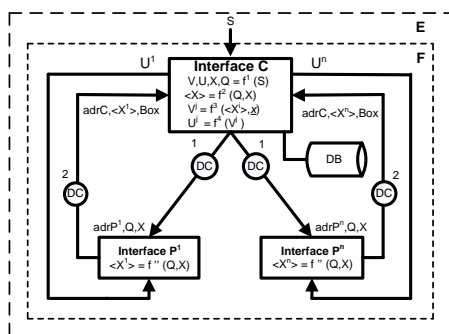

Fig.4 – System architecture

Center interface implements algorithms f1, f3, f4. Object interface implements algorithm f2. Realization of the obtained management is carried out by the corresponding center department outside the given scheme.

4. TECHNOLOGY AND SYSTEM

The architecture is realized in C# with the use of MS SQL Server 2005 when constructing a range of systems with the use of departmental communication lines. Information exchange (center-mediator-object-center) is based on XML. Architecture transparency contributed to quick mastering by personnel with different degree of training.

Application technology of the developed system includes the following main stages:

- construction of an unenriched model,
- sending of the model to distant objects,
- enrichment of the model by including the required information,
- sending of the enriched model to the center,
- analysis of the obtained information and development of management concerning each object.

The use of the technology is demonstrated by example of solving management problem for distributed software company.

The interface of the modeling and analysis is shown in Fig.5.

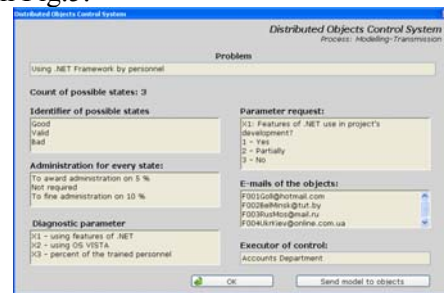

Fig. 5 – An interface of simulation and model delivery to an object

After sending of the unenriched model, object administration initiates enrichment of the model (Fig.6).

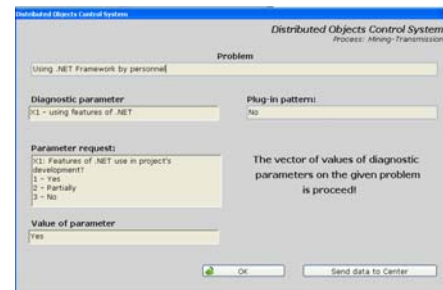

Fig. 6 – An interface of model enrichment and sending to the center

After obtaining of the enriched models from all objects the center initiates analysis of their states and the development of the corresponding management. (Fig. 7).

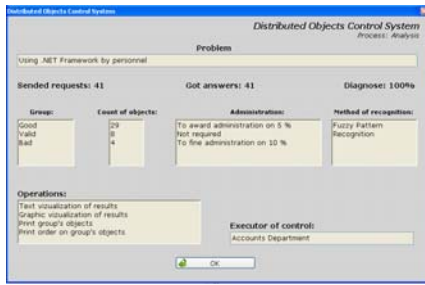

Fig. 7 – An interface of model enrichment and sending to the center

This system has allowed to exclude a role of the programmer and the engineer of knowledge from process of the decision of the given class of tasks.

CONCLUSION

The paper deals with problems of the development of systems for prompt management under uncertainty of distributed organizations. Fuzzy source data is typical for such problems. The necessity for developing a technology invariant to the number of objects is substantiated. The theoretical basis is the theory of active systems, which is enriched with components of the theory of fuzzy sets and communication.

The following main results are obtained:

- the problem of constructing a system for managing geographically distributed organizations on the basis of fuzzy information is formulated;
- center model, object management model, mediator model for information exchange are constructed;
- algorithms for recognizing object states on the basis of fuzzy data and the choice of the corresponding management are developed;
- an architecture of a computer system for realizing the developed models and algorithms invariant to the number of objects is developed.

REFERENCES

- [1] Mesarovich M., Mako D., Takahara Y. Theory of Hierarchical Multilevel Systems. – M.:Mir,1973. – 344 p.
- [2] Burkov V.N., Novikov D.A. Theory of Active Systems: State and Perspectives.– M.:Sinteg,1999.–128 p.
- [3] Tsaregorodtsev A.V. Theory of Construction of Hierarchical Information and Control Systems. – M.: RUDN, 2005. – 217 p.
- [4] Klir G., Elias D. Architecture of Systems Problem Solving. IFSR, Hardcover, 2003. - 354 p.
- [5] Zadeh A.L. The Role of Fuzzy Logic in

Modeling, Identification and Control, Modeling Identification and Control,1994,15(3).-P.191-203.

- [6] Krasnoproshin, V., Valvachev A., Vissia H. Unstructured Knowledge Synthesis for Decision–Making Problems // Proc. of the 7-th International Conference, PRIP’2003. – Minsk, 2003. – Vol. 1. – P. 145–149.
- [7] Krasnoproshin, V., Obraztsov V., Vissia H. Decision–Making by Precedence: Modeling, Technology and Applications //Proceedings of International Conference on Modeling and Simulation in Technical and Social Sciences (MS’2002). – Girona: Spain, 2002. – P. 267–277.



Ghazi Hussein Shakah was born in 1970. Graduated from Belarusian State University in 1995. Received candidate’s degree in 2006. Scientific interests: decision support system, artificial intelligence. Now is Assistant Professor in Irbed National University.

Author of 16 papers.



Krasnoproshin Victor Vladimirovich was born in 1947. Graduated from Belarusian State University in 1974. Received candidate’s degree in 1979 and Doctor of Sciences degree in 2007. Head of the Information Management Systems Department, professor. Scientific interest: decision-making theory, pattern recognition, and artificial intelligence. Author of more than 170 papers, including 5 monographs



Valvachev Alexander Nikolaevich was born in 1952. Graduated from Gorky State University in 1974. Senior staff scientist of the Information Management Systems Department, Belarusian State University. Scientific interest: artificial intelligence, knowledge modeling, fuzzy sets, active systems. Author of 7 monographs and 26 papers.