

Intellectual Scenario-synergetic Control of the Humidity and Temperature Regime of the Greenhouse Facilities

DMYTRO POLISHCHYK¹, VITALIY LYSENKO¹, SERHII OSADCHYI², NATALIA ZAIETS¹

¹National University of Life and Environmental Sciences of Ukraine, Kyiv, Ukraine
(e-mail: poli19poli94@gmail.com, lysenko@nubip.edu.ua, z-n@ukr.net)

²Central Ukrainian National Technical University, Ukraine, ivserg215@gmail.com)

Corresponding author: Dmytro Polishchuk (e-mail: poli19poli94@gmail.com).

ABSTRACT The article substantiates the management of the humidity and temperature regime of greenhouse complexes on the basis of a scenario-synergetic approach. The scenarios for controlling the temperature and humidity conditions in the greenhouse using the approach of fuzzy neural networks are formed. The structure of an automated control system for technological processes is developed, which provides automated collection and processing of information for the implementation of control actions in order to improve the efficiency of the greenhouse complex on the basis of a scenario-synergetic approach. The corresponding fuzzy neural networks are synthesized for a synergistic assessment of the interaction of technological parameters. Estimation of the root-mean-square error in the synthesis of fuzzy neural networks confirms the possibility of their use for the synergistic formation of scenarios for controlling the temperature and humidity regime in greenhouses to reveal the presence of a synergistic effect. Production rules for scenario management of temperature and humidity conditions are formed. It is shown that the use of fuzzy neural networks for the formation of scenarios for controlling the humidity and temperature regime provides the possibility of obtaining the appropriate scenarios for making managerial decisions and their prompt correction.

KEYWORDS intelligent control system; biotechnological object; greenhouse; mathematical filter; neural network; synergetic control.

I. INTRODUCTION

GROWING integration of technological approaches to the automation processes into the greenhouse production increases the resource efficiency, reduces the labor costs and increases the cost effectiveness of production [1, 2].

The traditional climate control systems within the under-cover greenhouse facilities which combine control and measurement systems for temperature, irrigation, additional lighting, CO₂ supply, ventilation as well as distributed sensor networks [25] are widely known [3, 4]. Providing that they are using peculiar software, such systems operate in two modes, automatic and semi-automatic. However, at the present-stage of development the computational intelligence systems demonstrate the following disadvantage – the control process does not take into account the crosscutting interrelation of the technological parameters, that is, when regulating one parameter leads to the divergence of others and the forecasted changes of the external environmental disturbances are not considered synergistically.

Consequently, adapting the existing methods of automating

the greenhouse facilities on the basis of their interactions in accordance with the limiting economic criteria is an urgent task.

II. RELATED WORK

Studying the works of Gao A., Chen H., Vögeling H., Lee Yongwei, Pozin G.M., Pryschev L.G., Stroy A.F., Takakura, Terence Belvins, Tkachenko V.A. and other scientists, experts proved that it is necessary to improve the existing microclimate control systems in the under-cover greenhouse facilities towards their comprehensiveness in terms of managerial decision making in order to come to a compromise between the energy expenditures and quality of the products [13-24].

Control systems were developed that provide intelligent formation of control strategies based on information received from a mobile robot [5, 26]. Also, control systems were developed for the process of growing tomatoes in greenhouses with algorithms for predicting external natural disturbances [6]. However, none of the existing control systems takes into account the synergistic effect of the mutual influence of

microclimate parameters in the conditions of forecasting changes in external natural disturbances.

Having studied the peculiar features of microclimate regulation in greenhouses, we can highlight the following possible ways of saving energy and increasing the profitability of production:

- reorganization and improvement of the traditional microclimate control systems by means of new methods and means of automated control in accordance with the technological requirements;

- costing of the energy expenditures using the real-time monitoring subsystems and the databases for storing and further analysis of the information collected;

- utilization of the heating systems which incorporate renewable energy sources (solar radiation, wind energy and geothermal water);

- designing the information flow control systems for the major technological parameters taking into account the interaction of microclimate parameters and the forecasting of external disturbances virtually on the basis of their emergence (synergy).

The implementation of synergetic approaches to support the decision making is regarded as particularly promising. Along with this, synergetics appeared in the 1960s as a physical and mathematical theory of the so-called dissipative systems, namely open systems which interact with the environment and maintain their existence through constant exchange of matter and energy with it [7]. In fact, the term “synergy” is equivalent to the concept of “joint efforts” and describes the following phenomenon: the result of joint efforts of the elements combined into a system ranks over the total sum of the results obtained by each element separately [8].

At the same time, the latest research works on synergetic management are published in the field of cybernetics and management of complex organizational and economic structures [9, 10]. However, it is common knowledge that the decay of many systems is due to their energy characteristics in the first place. There are two principal conditions for the destruction of integral systems [11]. The first of the two is formulated as follows: the system will be destroyed if the total momentum energy of the system exceeds the energy of its internal connections. The second condition for the destruction of integral systems is the following one: the system will cease to exist if the energy of internal connections is less than the sum of the total energy of external influences.

The very combination of modern computer integrated solutions and synergetic approaches constitute a promising prospect for controlling the humidity and temperature regimes of greenhouse facilities. However, since the process indicators in under-cover greenhouse facilities can be clustered in accordance with different indicators [12], it is advisable to combine the scenario mathematical apparatus with their emergence characteristics. The purpose of the research is to substantiate the control of the humidity and temperature regime of the greenhouse facilities on the basis of the scenario-synergetic approach.

III. MATERIALS AND METHODS OF RESEARCH

Energy changes in an isolated system are described through the second law of thermodynamics which was formulated as follows: heat energy alone cannot transfer from a colder body to a warmer one. The essence of this law is all about the decreasing ability of isolated systems to operate because the

energy is dissipating. The entropy formula determines the measure of disorder and chaos. The general formula for the degree of uncertainty (the amount of information in bits) looks as follows:

$$H = - \sum_{i=1}^N p_i \log_2 p_i, \quad (1)$$

where p_i is the probability of occurrence of an event S_i .

The formula of absolute negentropy is similar to the formula of entropy, only with a negative contribution. The “minus” sign in the right part of the above equation (1) is used to make the value of H positive (because $p_i < 1$, $\log_2 p_i \leq 0$, $\sum p_i = 1$).

In order to prevent the system from degrading, it is necessary to enter additional information (negentropy) into it. Negentropy is a certain, initially local state of violating the stability of the entropy growth process in the structured matter (information structure) which leads to an avalanche-like process of entropy reduction. Hence, the entropy of the system is a measure of disorganization while information is a measure of organization.

When evaluating the synergetic characteristics of the control system of the greenhouse facility, we assume that C_i ($1 \leq i \leq m$) represents the variety of actions that the system is capable of in a particular external environment. Suppose P_i represents the following probabilities: the system will choose any of the several courses of action in it. If these courses of action are exceptional and comprehensive, then

$$\sum P_i = 1. \quad (2)$$

Next, we assume that E_{ij} represents the probability that the course of C_i actions will provide for a certain O_j result. Then, the efficiency of the system, the function of which is to obtain the O_j result, will be as follows:

$$E_c = \sum P_i V_{ij}, \quad (3)$$

that is, the efficiency of the system is the probability of obtaining the desired result under the simultaneously fulfilled conditions: under the P_i probability, the C_i strategy is chosen and this strategy with the V_{ij} probability will ensure the achievement of the O_j result.

Since the phenomenon of synergy provides an additional effect in comparison with the sum of the total effect of the contribution by each of the elements of the system and this effect in each separate case can be defined, the synergy can serve as a measure of success for synergistic transformations. We introduce the k_c dimensionless synergy coefficient as such a measure, expressed by the following ratio:

$$k_c = E_c / \sum E_i, \quad (4)$$

where E_c stands for the full effect of the system with detected synergy, E_i – for the effect provided by the i -th component of the system.

Fuzzy neural network (FNN) approaches with the usage of the inverse error propagation algorithm have been used to design the control scenarios for the temperature and humidity regime in the greenhouse. The training includes the following steps [6]:

1. Certain η ($0 < \eta < 1$), E_{max} and certain small random weight ω_i of the network are set.
2. $k = 1$ and $E = 0$ is set.

3. The next training pair (x^k, y^k) is introduced. The following notations are introduced:

$$x := x^k, \quad y := y^k, \tag{5}$$

and the value of the network output is calculated:

$$O = \frac{1}{1 + e^{-W^T o}}, \tag{6}$$

where: W is the weight vector of the output neuron, o^k is the output vector of the neurons of the hidden layer with the elements:

$$o_i = \frac{1}{1 + e^{-\omega_i^T x}}, \tag{7}$$

where: ω_i denotes the weight vector associated with the i -th hidden neuron, $i=1,2,\dots,L$.

4. Correction of the weight of the output neuron is carried out:

$$W := W + \eta \delta o, \tag{8}$$

where:

$$\delta = (y - O)O(1 - O). \tag{9}$$

5. The weight of the neurons from the hidden layer is corrected:

$$w_i := w_i + \eta \delta W_i o_i (1 - o_i), i = 1, 2, \dots, L. \tag{10}$$

6. The value of the error function is corrected (increased):

$$E := E + \frac{1}{2} (y - o)^2. \tag{11}$$

If $k < N$, then $k := k + 1$ and go to step 3, otherwise go to step 8.

7. Completion of the training cycle. If $E < E_{max}$, then the entire training procedure ended. If $E \geq E_{max}$, then a new training cycle begins with the transition to step 2.

IV. RESEARCH RESULTS

The structure of the automated control system (ACS) for the technological processes (TP) has been developed in order to increase the efficiency of the greenhouse facility, which provides automated collection and processing of the information for the implementation of controlling effects aimed at increasing the efficiency of the greenhouse facility on the basis of the scenario-synergetic approach (Fig. 1).

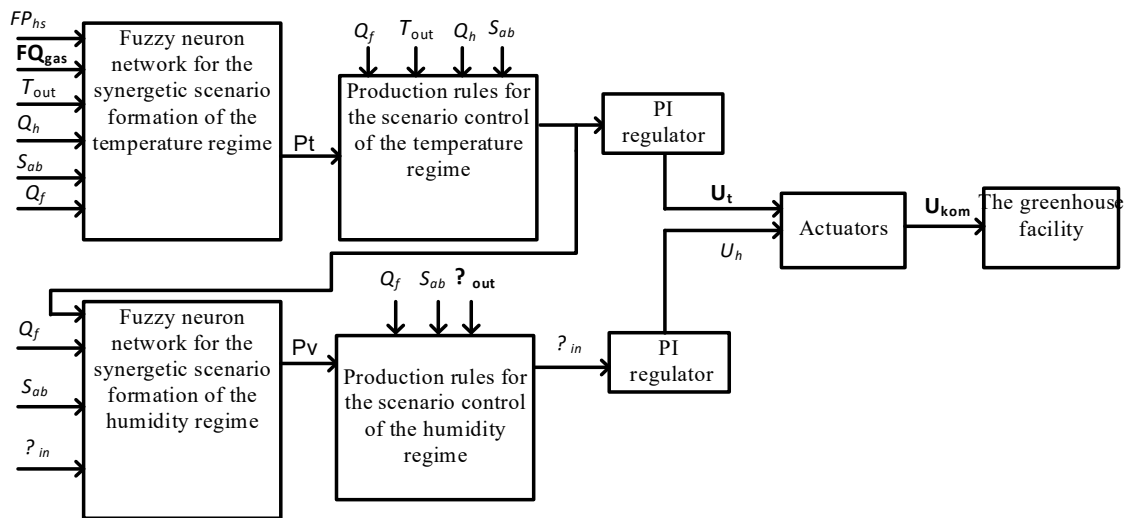

Figure 1. The control structure for the temperature and humidity regime of the greenhouse facility on the basis of the scenario-synergetic approach

Q_f - stands for the fogging system performance, T_{out} - for the air temperature outside the greenhouse, Q_h - for the power of the greenhouse air heaters, S_{ab} - for the solar radiation absorbed by the greenhouse, φ_{out} - for the relative air humidity outside the greenhouse, φ_{in} - for the given humidity inside the greenhouse, T_{in} - for the given temperature inside the greenhouse, P_t - for the knowledge base on temperature regime control, P_v - for the knowledge base on humidity regime control, U_{kom} - for the complex control action, U_t - for the temperature control action, U_h - for the humidity control action, P_{hs} - for the actual heating capacity of the heating system, FP_{hs} - for the forecasted heating capacity of the heating system, FQ_{gas} - for the forecasted gas expenditures.

The automated control system for the information flows of

the greenhouse facility is built on the principles of:

- hierarchical structure of the system;
- integration of the information flows from different levels of automated control systems into a unified system.

The design of such a control system is to be performed in several stages (Fig. 2).

Having obtained the statistical data from the enterprise "Combinat Teplychnyi" PJSC (the data is valid for the production year with discrete tracing every hour) the corresponding fuzzy neural networks (FNN) have been synthesized using the MatLAB package of applied mathematical programs for the synergetic evaluation of the interaction of technological parameters (Fig. 3).

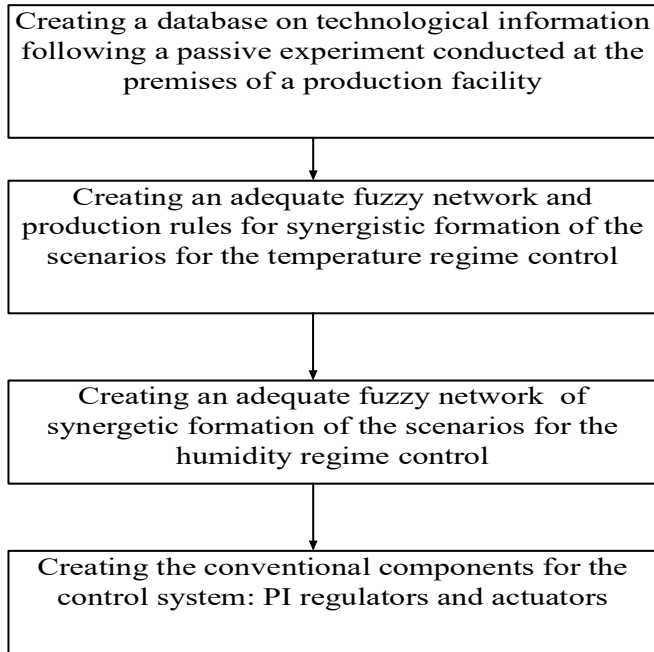

Figure 2. The sequence of synthesis of the control system for the humidity and temperature regime of greenhouse facilities on the basis of the scenario-synergetic approach

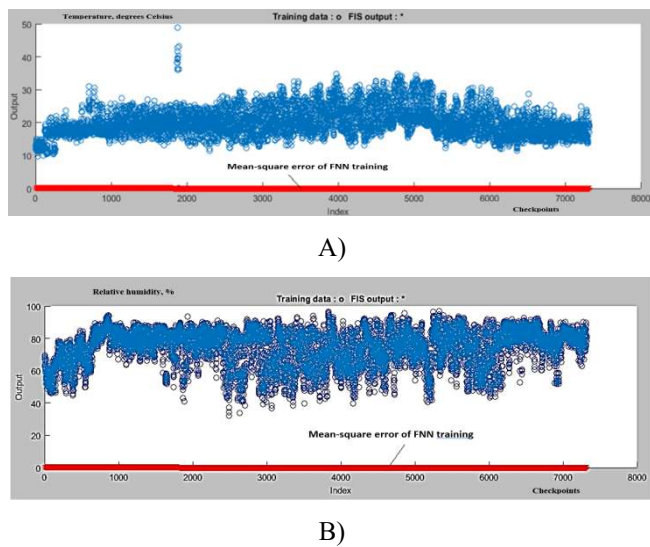

Figure 3. Evaluating the quality of functioning of the corresponding FNN of the synergetic scenario formation for the control of the temperature and humidity regime in the under-cover greenhouse facilities: A stands for the evaluation of the FNN efficiency through the temperature regime (the mean-square error equals 1.84%), B – for the evaluation of the FNN efficiency through the humidity regime (the mean-square error equals 1.12%)

Within the scope of the acceptable adequacy of the corresponding FNNs (Fig. 3) the production rules for the scenario control of the temperature and humidity regime have been formed using the ANFIS-Editor MatLAB software environment by means of the reverse error propagation algorithm (Fig. 4).

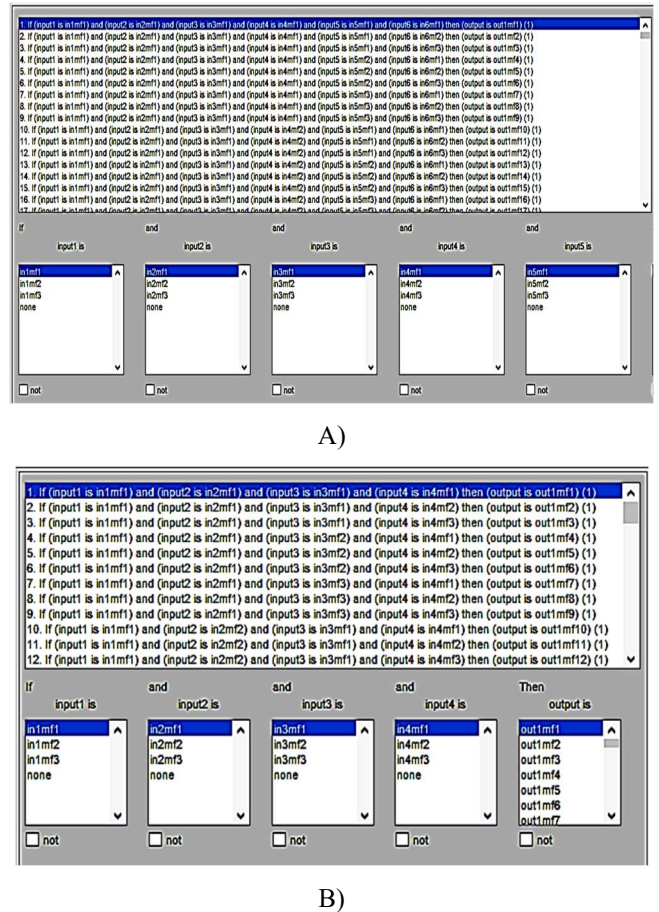

Figure 4. Production rules for the scenario control of the temperature and humidity regime of the greenhouse: A stands for the control of the temperature regime, B – for the control of the humidity regime

The presence of a synergetic (non-hermetic) effect has been evaluated on the basis of the created sequence (Fig. 5).

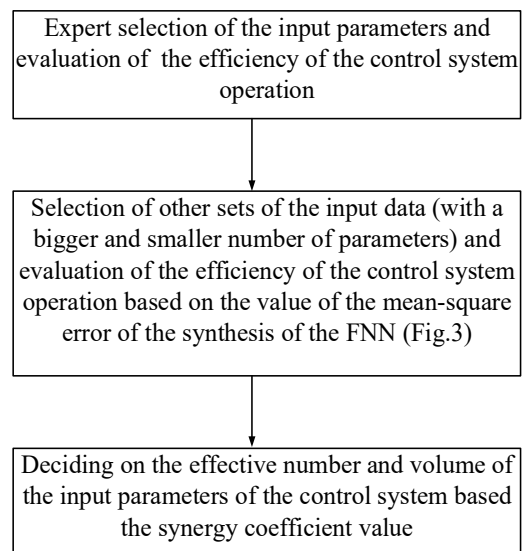

Figure 5. The sequence of setting the number of the input parameters for the control system of the humidity and temperature regime of greenhouse facilities based on the values of the synergy coefficient

Herewith, the number and volume of the input parameters from the proposed structure are taken as the basic level of functioning of the control system (Fig. 1). The arithmetical average value of the FNN training error under different combinations of inputs (their options) is considered to be equal to “1.0” and it serves as an analogue of the full effect of the system with the detected synergy from equation (4).

Calculation of the emergence criterion is as follows:

$$kc = (AAVTE\ FNNs)/(MSVTE\ FNNs). \quad (12)$$

AAVTE FNNs – stands for the arithmetic average value of the training error of all the *FNNs*, *MSVTE FNNs* – stands for the mean-square value of the training error of all the *FNNs*.

The mean-square error of training the specific conditions for evaluating the synergistic effect:

- if there is a synergistic effect present, the mean-square error of the neural network training will be more than 1.0;
- in case of negative transformation effect (negergia), the error value will be less than 1.0.

The same software settings of the ANFIS-Editor MatLAB environment are used here.

The following sets of input parameters have been selected as options:

- Option 1 (reduced number of inputs) – in accordance with the temperature: Q_f – stands for productivity of the fogging system, T_{out} – for the air temperature outside the greenhouse, Q_h – for the power of the air heaters in the greenhouse, S_{ab} – for the solar radiation absorbed by the greenhouse, FP_{hs} – for the forecasted heating power of the heating system, FQ_{gas} – for the forecasted gas consumption; in accordance with the humidity: T_{in} – stands for the temperature given inside the greenhouse, Q_f – for the productivity of the fogging system, S_{ab} – for the solar radiation absorbed by the greenhouse, φ_{out} – for the relative air humidity outside the greenhouse.

- Option 2 (basic) – corresponds to the terminology from the block diagram of Fig. 1.

- Option 3 (increased number) – in accordance with the temperature: Q_f – stands for productivity of the fogging system, T_{out} – for the air temperature outside the greenhouse, Q_h – for power of the air heaters in the greenhouse, S_{ab} – for the solar radiation absorbed by the greenhouse, FP_{hs} – for the forecasted heating power of the heating system, FQ_{gas} – for the forecasted gas consumption, φ_{in} – for the relative air humidity inside the greenhouse; in accordance with the humidity: T_{in} – stands for the temperature given inside the greenhouse, Q_f – for the productivity of the fogging system, S_{ab} – for the solar radiation absorbed by the greenhouse, φ_{out} – for the relative air humidity outside the greenhouse, T_{in} – for the temperature inside the greenhouse.

We obtained the values of synergy coefficients (Fig. 6) having evaluated the mean-square error of the *FNN* synthesis of the synergetic formation for the control scenarios of the temperature and humidity regime in the under-cover greenhouse facilities for different options and on the basis of the formula (12).

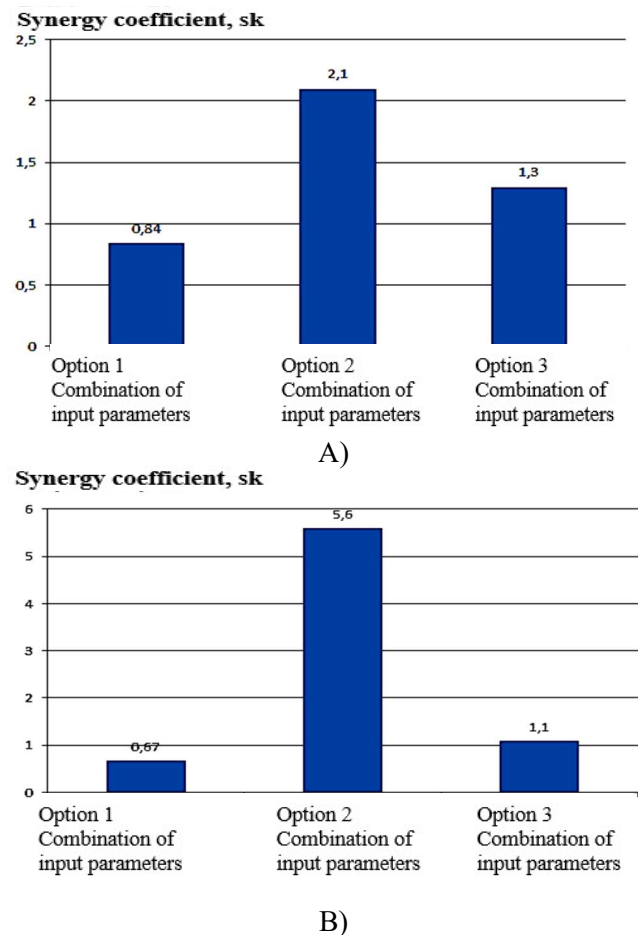

Figure 6. Values of the synergy coefficients for different options of combinations of input parameters: A) stands for training the *FNN* for the formation of control scenarios for the temperature regime (the arithmetic average error of training all the *FNNs* equals 3,86%), B) – for training the *FNN* for the formation of control scenarios for the humidity regime (the arithmetic average error of training all the *FNNs* equals 6.27%)

The obtained results have confirmed that the expertly defined initial sets of input data tend to be the most synergistically effective and can be applied for the control of the humidity and temperature regime of greenhouse facilities on the basis of the scenario approach.

VI. CONCLUSIONS

The phenomenon of synergy provides an additional effect when compared to the total effect of the contribution of each separate element of the system, while synergy is a measure of success of synergistic transformations, which, in case of forming the microclimate in the under-cover greenhouse facilities, establishes the need for evaluating the emergence of the influence of the technological parameters onto the quality of control and its adaptive real-time accountancy.

The application of fuzzy neural networks for the formation of control scenarios for the humidity and temperature regime (the mean-square temperature error equals 1.84%; the humidity error equals 1.12%) provides the opportunity of obtaining the

appropriate scenarios for managerial decision making and their timely correction.

Further research should be targeted at integrating the control system of the humidity and temperature regime at greenhouse facilities on the basis of the scenario approach to the information flow control unit through the usage of machine learning technologies and the Internet of Things.

References

- [1] T. Boulard, S. Wang, "Greenhouse crop transpiration simulation from external climate condition," *Agricultural and Forest Meteorology*, vol. 100, issue 1, pp. 25–34, 2000. [https://doi.org/10.1016/S0168-1923\(99\)00082-9](https://doi.org/10.1016/S0168-1923(99)00082-9).
- [2] H. Challa, "Integration of explanatory and empirical crop models for greenhouse management support," *Proceedings of Models. Plant Growth, Acta Hort.*, vol. 507, pp. 107-115, 2007. <https://doi.org/10.17660/ActaHortic.1999.507.12>.
- [3] A. Kichah, P. E. Bournet, C. Migeon, T. Boulard, "Measurement and CFD simulation of microclimate characteristics and transpiration of an impatiens pot plant crop in a greenhouse," *Biosystems Engineering*, vol. 112, issue 1, pp. 22–34, 2012. <https://doi.org/10.1016/j.biosystemseng.2012.01.012>.
- [4] D. Koshkin, "The dynamic model of the greenhouse environment control system," *Motrol, Lublin*, tom 13A, pp. 189–195, 2011.
- [5] A. Chochowski, I. Bolbot, V. Lysenko, V. Reshettiuk, "The optimization of energy efficiency of mobile robots," *Annals of Warsaw University of Life Sciences – SGGW. Agricultural and Forest Engineering*, no 70, pp. 79–88, 2017. <https://doi.org/10.22630/AAFE.2017.70.20>.
- [6] S. S. Mehta, T. F. Burks, W. E. Dixon, "Vision-based localization of a wheeled mobile robot for greenhouse applications: A daisy-chaining approach," *Computers and Electronics in Agriculture*, vol. 63, issue 1, pp. 28-37, 2008. <https://doi.org/10.1016/j.compag.2008.01.013>.
- [7] A. O. Dudnyk, N. A. Zaiets, T. I. Landel, M. A. Hachkovska, I. Yu. Yakymenko, *Development of Resource-efficient Modes of Growing Vegetable Products in Greenhouse Complexes: monograph*, Kyiv: Princeeko, 2020, 277 p. (in Ukrainian)
- [8] S. G. Oparin, "Sinergy in integrated systems of risk management sinergy in integrated systems of risk management and its accounting in the digital economy and its accounting in the digital economy," *Issues of Risk Analysis*, vol. 17, issue 6, pp. 50-61, 2020. (in Russian). <https://doi.org/10.32686/1812-5220-2020-17-6-50-61>.
- [9] A. V. Kovaleva, "Development models and strategic management of the company," *Audit and Financial Analysis*, no. 1, pp. 1-7, 2008.
- [10] D. A. Novikov, A. A. Ivashchenko, *Models and Methods of Organizational Management of Innovative Development of the Firm*, Moscow: Combook, 2006, 336 p.
- [11] *Systems Theory and System Analysis in the Management of Organizations: Tutorial*, edited by V. N. Volkova, A. A. Emelyanova, Moscow: Finance and Statistics, 2006, 848 p. (in Russian)
- [12] V. Lysenko, B. Golovinskyi, V. Reshettiuk, V. Shcherbatyuk, V. Shtepa, "Energy-efficient modes for management of biotechnical objects based on natural disturbances prediction," *Annals of Warsaw University of Life Sciences – SGGW Agriculture*, no. 65, pp. 111-118, 2015.
- [13] A. Gao, H. Chen, A. Hou, K. Xie, "Efficient antimicrobial silk composites using synergistic effects of violacein and silver nanoparticles," *Materials Science and Engineering: C*, vol. 103, 109821, 2019. <https://doi.org/10.1016/j.msec.2019.109821>.
- [14] H. Vögeling, N. Plenagl, B. S. Seitz, L. Duse, S. R. Pinnapireddy, E. Dayyoub, et. al., "Synergistic effects of ultrasound and photodynamic therapy leading to biofilm eradication on polyurethane catheter surfaces modified with hypericin nanoformulations," *Materials Science and Engineering: C*, vol. 103, 109749, 2019. <https://doi.org/10.1016/j.msec.2019.109749>.
- [15] G. Hossine, K. Katia, "Improvement of vector control of dual star induction drive using synergetic approach," *Proceedings of the 2017 14th IEEE International Multi-Conference on Systems, Signals & Devices (SSD)*, 2017, pp. 643-648. <https://doi.org/10.1109/SSD.2017.8167006>.
- [16] S. Prophet, J. Atman, G. F. Trommer, "A synergetic approach to indoor navigation and mapping for aerial reconnaissance and surveillance," *Proceedings of the 2017 IEEE International Conference on Indoor Positioning and Indoor Navigation (IPIN)*, 2017, pp. 1-8. <https://doi.org/10.1109/IPIN.2017.8115919>.
- [17] K. Li, X. Qi, B. Wei, H. Huang, J. Wang, J. Zhang, "Prediction of transformer top oil temperature based on kernel extreme learning machine error prediction and correction," *Gaodiyana Jishu/High Voltage Engineering*, vol. 43, no. 12, pp. 4045–4053, 2017. <http://doi.org/10.13336/j.1003-6520.hve.20171127032>.
- [18] S. Prophet, J. Atman, G. F. Trommer, "A synergetic approach to indoor navigation and mapping for aerial reconnaissance and surveillance," *Proceedings of the 2017 IEEE International Conference on Indoor Positioning and Indoor Navigation (IPIN)*, 2017, pp. 1-8. <https://doi.org/10.1109/IPIN.2017.8115919>.
- [19] Q. Gao, M. Zribi, M. Escorihuela, N. Baghdadi, "Synergetic use of Sentinel-1 and Sentinel-2 data for soil moisture map-ping at 100 m resolution," *Sensors*, vol. 17, issue 9, 1966, 2017. <https://doi.org/10.3390/s17091966>.
- [20] X. Zhang, L. Che, M. Shahidehpour, A. S. Alabdulwahab, A. Abusorrah, "Reliability-based optimal planning of electricity and natural gas interconnections for multiple energy hubs," *IEEE Transactions on Smart Grid*, vol. 8, issue 4, pp. 1658–1667, 2017. <https://doi.org/10.1109/TSG.2015.2498166>.
- [21] T. Takakura, "Research exploring greenhouse environment control over the last 50 years," *Mathematics and Computers in Simulation*, vol. 167, pp. 19–31, 2020. <https://doi.org/10.25165/j.ijabe.20191205.5179>.
- [22] T. Blevins, W. K. Wojsznis, M. Nixon, *Advanced Control Foundation: Tools, Techniques and Applications*, International Society of Automation (ISA), Research Triangle Park, NC, 2013.
- [23] H. Liu, S. Fang, X. Guo, "Research and design of intelligent greenhouse control system based on AIoT fusion technology," *IOP Conf. Ser.: Earth Environ. Sci.*, vol. 474, 032036, 2020. <https://doi.org/10.1088/1755-1315/474/3/032036>.
- [24] J.-T. Ding, H.-Y. Yao, Z.-L. Zang, M. Huang, S.-J. Zhou, "Precise control and prediction of the greenhouse growth environment of *Dendrobium candidum*," *Comput. Electron. Agric.*, vol. 151, pp. 453–459, 2018. <https://doi.org/10.1016/j.compag.2018.06.037>.
- [25] A. Sachenko, V. Kochan, V. Turchenko, V. Tymchyshyn and N. Vasylykiv, "Intelligent nodes for distributed sensor network," *Proceedings of the 16th IEEE Instrumentation and Measurement Technology Conference (IMTC/99)*, 1999, pp. 1479-1484 vol. 3. <https://doi.org/10.1109/IMTC.1999.776072>.
- [26] O. Vdovichenko, A. Perepelitsyn, "Technologies for building systems of remote lining of communication lines: a practical example of implementation," *Radioelectronic and Computer Systems*, no. 2, pp. 31-38, 2021. <https://doi.org/10.32620/reks.2021.2.03>.



Dmytro Polishchuk, a Postgraduate student. Department of Automation and Robotics Systems named after acad. I. I. Martynenko, National University of Life and Environmental Sciences of Ukraine



Vitaliy Lysenko, PhD., a Professor, Department of Automation and Robotics Systems named after acad. I. I. Martynenko, National University of Life and Environmental Sciences of Ukraine



Serhii Osadchii, PhD., a Professor, Department of Automation of Production Processes, Central Ukrainian National Technical University



Natalia Zaets, PhD., an Associate Professor, Department of Automation and Robotics Systems named after acad. I. I. Martynenko, National University of Life and Environmental Sciences of Ukraine.

...